

Sophie Steffanoni (1873 - 1906) Sydney Impressionist Artist.
Harvest Time Threshing, 1898. Oil on canvas 33 x 49cm. Reproduced with permission.



Safe in the Shed

Caring for Historic Farm Machinery





Emerging wheat crop. Furrow lines in a paddock.
*Photograph by Angus McGeoch, Wagga Wagga.
Reproduced with permission.*



The old way of doing things. "This is a single furrow plough usually pulled by two horses in the very early days, it being the biggest plough used. Originally, it would have been used before sowing wheat which would have been hand broadcast, then harrowed to get it into the ground, so it could germinate. This is how the name 'cocky' originated because the grain was not under the ground very far and the galahs would come along and eat it. Draught horses were used".
*Photo and description from the Garth Jones Collection,
courtesy Coolamon Shire Council.*



Felling trees and feeding horses. "This horse feed trough was purchased from Tony Wotton (from a property called) 'Ricka Veera', Ardlethan. It was first used by his grandfather in the very early 1900s. It is thought that it may have been made out of a hollow tree, killed or felled when the clearing was done by Chinese workers in the late 1800s. It sits on the original blocks".
*Photo and description from the Garth Jones Collection,
courtesy Coolamon Shire Council.*



'Deloraine' homestead on a wheat and sheep farm at Tarcutta, NSW. Historic farm machinery relates to people and places.
Photograph by Angus McGeoch, Wagga Wagga. Reproduced with permission.

'Safe in the Shed' was written as a result of the NSW Heritage Office and Ministry for the Arts Movable Heritage Project thematic study on the Riverina wheat industry. This was researched by the Museum of the Riverina in collaboration with local museums and historical societies, farmers, local government heritage advisors and the regional museums officer. The study aims to investigate the Riverina wheat industry and to identify, conserve and interpret rural technology through assessing significance and reconnecting machinery with the landscape and farming context in which it was used.

cover

Storing the harvester. Stripper-harvesters combined threshing (cutting) and winnowing (removing the grain from the chaff) in one machine, saving time and money because labour and machine costs were greatly reduced and harvesting could be done more quickly. Farms were labour intensive. Work was shared between husband and wife, and their children helped with chores. There were also regular and itinerant labourers. The arrival of new farm machinery was often a great family occasion because the expensive new technology made the farm more productive. As the family's economic future depended on the machinery, it was looked after carefully. Like machinery still in use, historic machinery can usually survive for long periods on the farm where it belongs, providing there is basic security, protection from pests and shelter from the elements.

Original photograph by Charles Kerry Studio, Tyrrell Collection, the Powerhouse Museum, Sydney. Reproduced with permission.

Why is historic farm machinery important?

Heritage is evidence of our history and way of life. Historic farm machinery shows us how our industries, farms, work practices and communities have changed over time. Farm machinery can also help us to understand the impact of European settlement on the landscape. It reminds us of the old ways of doing things and helps pass on traditional skills and trades to a new generation.

We usually think of historic machinery as examples of old-fashioned technology. But can you explain how and where it was used, who owned it and the stories about working with it? Did the machinery change the local labour market, family life or your region's economy? Was it invented or manufactured locally?

Some people may remember these things, but their memories and experiences are rarely written down or recorded. In most cases the way the machinery is catalogued, labelled and presented in museums does not do justice to the stories it can tell us about people, places and the hard labour of farming life.

These farm stories need to be recorded and told before they are lost or forgotten, so they can be passed on to the next generation. Historic farm machinery needs to be looked after through careful conservation decisions and writing down its history.

Who is this publication for?

This publication is for museums and historical societies with heritage collections, museum advisors and private collectors. It also aims to help farmers and anyone interested in historic farm machinery to capture stories and record and care for the machinery in their region.

'people, places and farming life'



Understand your farm machinery and your region's story

A short history of your region can help you to better understand the history of agriculture and farm machinery. It helps to pool local knowledge, including the experiences and memories of using machinery.

Researching history provides a context for understanding the machinery and where it fits into the region's story and the processes of the industry. You can research it yourself or engage a local person trained in writing history. A history can be an illustrated paper with photos and captions. It does not have to be long and wordy.

- Talk to family and friends who may remember the machines. Also talk to experts, including people who used the machinery like local farmers and former employees. Don't forget to talk to women, agricultural advisors, machinery sellers and repair shops.
- It is a good idea to interview people with the items and at the places they worked to trigger memories and stories. Where possible, photograph the people who tell you about the items. You can use these photos in exhibitions.
- Research the existing history and information on the machinery and the local industry in local libraries and historical societies. Don't forget information about the places and groups of people who are associated with it, for example, a group of workers or a cultural community.

Sample interview questions

Before starting your interviews with people, jot down your key questions and ask:

Who used it? What was it like to use the machinery?

What was the farming context – name of property, land issues and family structure?

What difference did it make to working on the farm?

What machine did it replace? How long was it used for and how widely in the region?

What other machines was it used with?

Was the machine designed for the local environment to solve a particular local problem, for example, rocks or weeds? How was it modified?

Remember, the human story is as important as the technology and design changes. Consider both.

- Find old photographs, especially ones of people using the machinery. This could inform you about how it was used and where, maybe with other machinery along side it. Often the arrival of new machinery was a great occasion (and expense) recorded in photos. Photos of items in use bring a human aspect to machinery display labels.
- Carefully examine the machinery to see how it was used, looking for evidence of wear and tear, repairs and adaptation. These changes are an integral part of the machine's history.
- Look for information on the regional economy, settlement, transport, family relations, working life, local labourers (including Aboriginal and migrant communities) and the impact of the machines on the local environment and landscape. They can also reflect evidence of droughts, fires, floods, insects, diseases and eradication efforts.
- Drawing from the history, identify the main themes in your region's history and express them as activities or processes, for example, "ridding rust from wheat" and "clearing the land of rocks and trees". Prepare a timeline of key events in the history of the region and the industry. Map out the key types of technology used in the industry and trace the work processes, step by step, so that other people can understand them.
- If the machinery is located on an old farm it contributes to the overall interest of the place. Where possible protect it on site. Research it in the context of working and living at that farm, as well as the industry. Photograph the old machinery in its context of use, for example, in the field where it has been used and with the people who used it.
- Add all the information about the machinery to the regional history and if you are a museum, to the catalogue information, so that it is a complete account. This will keep alive the distinctive stories of your region. You can use this information in displays, exhibition labels, brochures and other publications.

The story of wheat

The Museum of the Riverina is researching a history of the Riverina wheat industry and its machinery. This includes tractors, steam engines and other power sources, ploughs, harvesters, hay balers, farm implements and hand tools and any items that would have aided the wheat industry in ploughing, planting, harvesting, storing and transporting wheat to silos and flour mills.

Looking beyond just technology, the Museum is researching transport and land usage and local farms and flour mills and how the machinery related to the division of labour in families, working life and the local labour force. It is outlining all the steps in wheat production and how these relate to quality flour products for domestic and industrial use. The Museum is also preparing a list of the key historic themes of the industry and surveying the types of technology used in relation to the themes.

The history tells the story of the Riverina wheat paddocks and the quest for good flour and reliable wheat varieties and pioneering efforts to overcome problems with pests and diseases, fires, droughts and floods, and how machinery was designed to cope with wheat harvesting and to improve productivity. It is revealing that men and women shared responsibility and labour for running the wheat farms.

Once the history is completed, the museums in the Riverina will review their collections to see how the machinery reflects and tells the story of the wheat industry and the Riverina region's history. The museums will review their displays to tell the story of the industry, its people and farming practices.

Themes drawn from a history are a tool to help us understand why items of farm machinery are important and where they fit in.

The Museum of the Riverina has identified historic themes in the Riverina wheat industry including:

Women working on the farm,

Managing hazards on the farm (fires, floods, droughts, diseases and pests),

Milling and baking with wheat, and

Preparing the land for agriculture and harvesting.



Pearce's Improved Cahoon's Patent Broadcast Seed Sower. Drawing from 'Lassetters Commercial Review', No 26, 1911.

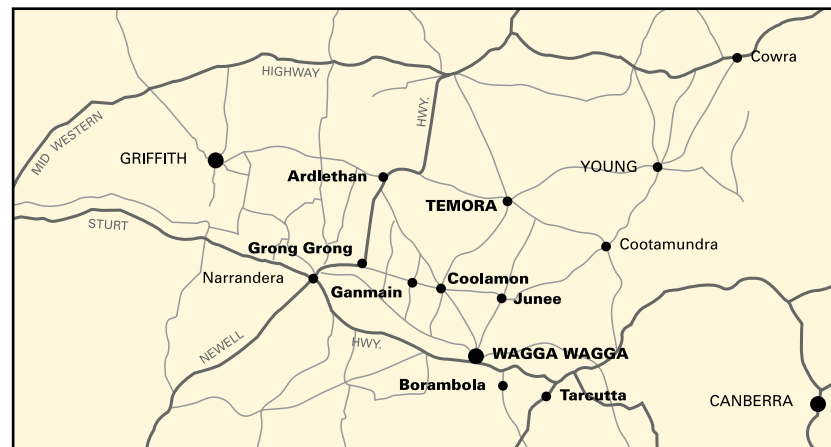

Towns featured in this publication are highlighted in bold.

Reaper-binders cut the wheat crop at the base of the stalk and tied it into neat sheaf bundles, which were then pushed onto the ground. The bundles of sheaves were then collected and arranged in stooks for drying. Stripping, by contrast, knocked off the heads of grain and left the stalks standing. Both processes required further action to remove grain from the chaff – threshing was done to obtain the grain, with reaping and winnowers used in association with strippers. *Original photograph by Charles Kerry Studio, Tyrrell Collection, the Powerhouse Museum, Sydney. Reproduced with permission.*



Wheat heads and stalks in a stook. Stooks are bundles of sheaves in groups of about ten, that are placed upright in the paddock for drying in the summer sun before being carted away to be used as the “bricks” for building a haystack. *Photograph by Angus McGeoch, Wagga Wagga. Reproduced with permission.*



Haystack, Ganmain, NSW. Sheaf turners passed each sheaf to the stack builder who would lay them with great care to provide stability and sloping sides to deflect rain. Haystacks resembled giant loaves of bread in the landscape and were proud monuments to teamwork and skill. The hay was used to feed livestock, in particular horses, during the barren dry months. Stooks and the loaf shape of haystacks, once a common sight in the Riverina, are now only seen in the Ganmain district. *Photograph courtesy Kylie Winkworth.*



Men using pitchforks to load wagons with stooks. The most important and difficult part of haymaking was to decide when the stooks were safe enough for stacking. If there was too much moisture left in them, they could overheat, ignite and result in the complete loss of the haystack. An additional hazard was snakebite and great care was taken to ensure snakes were not lurking in the stooks. When full, each wagon would travel to where the stack would be built and then unloaded.

Original photograph by Charles Kerry Studio, Tyrrell Collection, the Powerhouse Museum, Sydney. Reproduced with permission.

Assessing significance

To understand how best to care for historic farm machinery, assess its significance to guide decisions such as storage, restoration or conservation. Assessing significance is a process that helps you to understand the meaning and importance of an object or place. It can also determine which items are the most important in your collection or region and focus your efforts and resources. Survey your museum and see which machines are in the collection. Where do they fit into the timelines, types, work processes and historic themes and the context of the history?

What is significance?

Significance means the historic, aesthetic, scientific or research and social or spiritual values (for example, a community has a long-standing and out of the ordinary attachment to a particular machine) of farm machinery for past, present and future generations.

The criteria used for assessing objects and museum collections are:

Historic significance

Important for its associations with people, events, places and themes. This could include industries and places, events and all kinds of people who have been important in the history of your region.

Aesthetic significance

Important for its craftsmanship, style, technical excellence, beauty, demonstration of skill and quality of design and execution. This could include machinery that is a one-off, perhaps manufactured locally and well made, or machinery that is mass-produced. It could include an item with original paint finishes and decorative detailing which show the skill of the signwriter or manufacturer's craft.

Scientific or research significance

Important for its major potential for further scientific examination or study. This includes machinery with potential to yield further information in a subject area, for example farming methods, or making do with scarce resources, especially where it represents aspects of history which are not well reflected in other sources.

Social or spiritual significance

Important because the item is held in community esteem. This may be demonstrated by social, spiritual or cultural expressions that provide evidence of a community's strong affection or how it contributes to that community's identity and social cohesion. For example, a particular machine might be a prized item in your community and may be a long-standing focus for crowds at museum open days.

There are also criteria for assessing the **degree** of significance of different items.

Provenance

This means the chain of ownership and context of use of an object. Knowing this history enables a more precise assessment.

Where there are two items of the same machinery and we know the history of place and people associations and other stories of one but not the other, the one with the documented provenance would be generally more significant, assuming they are the same in all other aspects.

Representativeness

An item may be significant because it represents a particular category of machinery, or activity, way of life or historical theme. It could be a good example of a type of machine or one that illustrates a farm process or activity of historic interest.

Rarity

A machine may be significant as a rare, unusual or particularly fine example of its type.

Condition, intactness and integrity

A machine may be significant because it is unusually complete, or in sound original condition. This is an important criterion for machinery which could be diminished or destroyed by restoration. A machine with its original finishes, signwriting and parts, or showing evidence of use and adaptations during working life, will generally be more significant than one that has been restored. This criterion may help museums decide when to keep a collection of related farm machinery together as a whole.

Interpretative potential

This aspect is of particular interest to museums. Historic farm machinery may be significant for its capacity to interpret and demonstrate aspects of experience, historical themes, processes and activities. It has potential to tell stories, educate visitors and assist us in understanding aspects of natural or cultural history.

Write a statement of significance

Using the above criteria and your history and themes, write a short statement of significance to explain why the machinery is important in the region's history and for its manufacture and associations with people, events, places and themes. Include this in the catalogue documentation.

Once we know the values and meanings of an item and why it is important, we are able to make informed decisions about how to care for it, including what level of conservation is necessary and the most practical way to maintain it.





The foundry at Junee, NSW was established in 1893 by two immigrants, Arthur Walster from England and Andrew Cohoe from Canada. Pictured are two generations of the Walster family who operated the foundry. David Walster assisted the Museum of the Riverina's oral histories. It is a good idea to interview people with the objects and in the place where they were made or used.
Photograph courtesy David Walster.

Cohoe and Walster stripper

The stripper is significant in the history of the wheat industry in the Riverina and demonstrates typical working practices used from the late 19th century until the 1920s. It was pulled by horses and stripped the heads of wheat from the crop. The technology was an 1840s Australian invention that revolutionised the wheat industry. It improved profits, efficiency and reduced labour costs. The stripper replaced the skills of the reaper, gatherer, binder and stookers with one machine.

In fact, one stripper was worth 14 labourers and could harvest six times faster than by hand and at one third of the cost. The Cohoe and Walster foundry in Junee made a range of agricultural tools and machinery.

The stripper is one of the few surviving examples of machinery produced there and is the only known stripper from the foundry still in existence. It also has associations with Arthur Walster and Andrew Cohoe of the foundry and the Tokley family and their property Avondale Park, near Coolamon, where it was used between 1901 and the 1930s. It is also associated with the Riverina because it was contracted for use by other farmers in the region during this period.

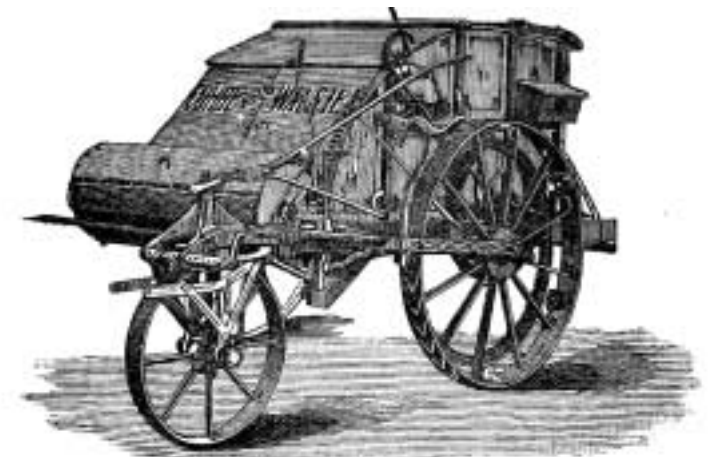

COHOE & WALSTER'S BELT GEAR DAMP WEATHER STRIPPER.

The Cohoe and Walter stripper at the Museum of the Riverina is maintained in almost original condition. Parts of the stripper have old faded pencil and pen notes written on it by the farmer which tell us about his work. Repainting would have erased this important information.
Drawing courtesy Museum of the Riverina.

Museum issues

- Develop a collection policy. A good policy entails assessing significance, so include a statement about assessing the significance of your collection, and the relationship of historic farm machinery to places and people. This will help you make better collecting decisions and inform you if collecting or moving farm machinery will have an adverse impact on its significance, including the farm it may be located on. A collection policy should include provisions for removing items from a museum collection, when they have little or no significance and also promote working in co-operation with other museums in your region.
- If you are thinking of disposing or deaccessioning an item from your museum, contact the Museums and Galleries Foundation of NSW for advice and help in making an informed decision.
- It does not need to be in a museum to be part of our heritage. Historic farm machinery in its original place of manufacture or use, or in a family or place with which it has a long association, has great significance. You can assess the significance of the machinery as an important element of the farm or as part of the family's heritage. It may be a potential family heirloom. Try to keep the machinery in its place of use, perhaps in storage. Moving the item is likely to diminish its significance as part of your region's heritage and it may not be a suitable item to have in your museum.
- If you have assessed the significance of historic machinery, your museum can use its skill to help owners document and conserve the machinery on the farm where it is located. If you have assessed the significance of the item and its relationship to the place where it is located, and it is appropriate to collect it, make sure that you record its stories, its history of use at the place and with people in the region. Take photos of the machinery at the farm before it is collected, for example, the shed where it is stored or field where it was used. If possible, ask the donor to write down their recollections of the machine. Write a statement of significance and consider its relationship to the place and its people. Keep one copy of the documentation at the farm and the other in your museum catalogue.
- Keep in contact with your local shire's heritage or museums advisor and other community museums and historical societies in the region and work together. Are you telling the story of your town or your region? What is your town's part in the region's story? How does your collection of farm machinery communicate the story of the place and the lives and activities of local people? Consider concentrating on one aspect of farming or industry if a nearby museum has similar interests. Avoid creating duplicate collections.

- Before collecting machinery, be sure that you can care for it adequately. Store it under cover. There is no point removing machinery from a farm to have it stand in the weather outside your museum. Is it already cared for on the farm as part of your region's heritage? If so, there may be no need to collect it.



Swinging on the gate. Removing items from their place of use requires careful assessment of significance. The meaning of an item is often closely related to its place of use and working life. If you are collecting from farms, make sure the item is photographed and fully recorded before it leaves the farm. This material will help you interpret the item in your museum.

"This to me is one of the most interesting pieces in my museum. It is a gate made by H. V. McKay, Sunshine. I believe it was one of the first gates in the Cowabbie district, erected by my grandfather, Adolph Pfrunder of 'Baden' Grong Grong. He was born 27th November, 1859 and migrated from Baden Baden, Germany, at the age of 19. My mother told me she used to swing on the gate on her way to school, approximately in 1904. The story goes ... one of my neighbours saw my mother swinging on the gate and told my grandfather about it. He was most incensed that the man thought that a gate swung by him wouldn't take the weight of one small child..." Photo and description from the Garth Jones Collection, courtesy Coolamon Shire Council.

Caring for historic farm machinery

How do we conserve it? Look at the evidence and examine the significance.

Restoration means returning farm machinery to a known earlier condition. It might mean removing or covering signs of wear and other evidence of its working life and manufacture and reassembling existing components, for example, ones that were removed.

Reconstruction means adding new materials like parts and paint.

Preservation means maintaining the farm machinery in its existing condition and trying to slow further deterioration.

Your statement of significance will help you understand the special characteristics of the machinery and what makes it important. It will guide you on appropriate ways to conserve and maintain the item.

If you are proposing changes to the item, consider how this may affect its significance. Could the changes be completely reversed in the future without any damage to the item? Here are some things to consider:

- It is best to preserve farm machinery that is of historic, aesthetic, scientific or research and social or spiritual significance. The same goes for machinery that is rare, representative, intact or in sound original or complete condition for its age and use, or with documented provenance.
- Seek expert advice and investigate the item's significance before starting any conservation or restoration work.

- Avoid reconstruction and restoration wherever possible. Repainting and replacing original parts with new ones, or old ones from elsewhere, can mean that the original components and finishes of the machinery are destroyed. This means that the fabric of the machine can no longer demonstrate its working history and its cultural value has been diminished. Do not repaint or replace parts on machinery that is rare, intact or in sound original or complete condition for its age and use, compared to other items. Do not repaint or replace parts on significant machinery that was manufactured locally or strongly associated with the region's people, events, places, historic themes and industry. Do not return a machine to an earlier condition without evidence and avoid conjecture.
- Machinery demonstrations are popular in many museums, however, making a machine safe for contemporary demonstrations often entails extensive repair and replacement, possibly diminishing the machine's significance. It is preferable to choose a less significant machine to restore to operating condition.
- If you have a complex machine or piece of equipment, consider preparing a conservation management plan before working on the object. This will identify why the machine is significant and recommend how to care for it to retain its significance. The NSW Heritage Office and Ministry for the Arts provide funding for conservation management plans. Works recommended in plans can also be funded.
- Take detailed photographs of the machinery in original condition and prepare measured drawings. Add these to your catalogue documentation. Keep a photo record of any changes to the item.

Cook's galley

This cook's galley is significant in the history of grain farming in the Riverina as a rare surviving and intact example of a mobile galley. It was part of a chaff cutting plant that was drawn and powered by a steam traction engine which operated during the 1930s to the 1950s. The plant comprised a traction engine, water cart, chaff cutter, steam box and galley.

The galley was a mobile kitchen used to prepare food to feed the chaff cutting team. It was made on the chassis of a gravel wagon that was extended to create a platform for the kitchen. Its recycled materials, cooking utensils and other contents, including enamel plates, add a human aspect which demonstrate the working life of the cook and labourers who worked the machinery on a number of farms in the Riverina. The galley is associated with its owner, the Fife family which contributed to the economy and political life of the Riverina. Its bumps and marks on its tin canopy tell us about the difficulties of moving such equipment under trees and through rough terrain. Under the galley, there are fragments of a water bag and evidence that the cook slept underneath it at night. The pan to fry the chops shows the skill and range of work of the local blacksmith.

The Museum of the Riverina has prepared a conservation management plan to understand the significance of the galley and make informed decisions about how to care for it to conserve its significance. The Museum analysed the galley's fabric, made measured drawings and photos of the galley and recorded its regional associations, history of use and the working life of the cook and the gang that worked on the wheat fields. Old photos of the galley in use were copied and details of the gang's working day and lunch were recorded.

Because of the galley's historic and research significance, rarity, intactness and its unique interpretive potential to tell us about working in the Riverina paddocks, it was decided the galley would be conserved in its original condition without repainting or repairs to dents and broken panels. To do otherwise would change the character of its appearance and diminish its ability to tell stories about the bumps and daily grind of wheat field life and how the workers had to make do when building materials were scarce. Restoration and even cleaning, would risk losing the water bag threads and other marks that are evidence of an earlier way of life that is now largely forgotten.



The cook's galley and utensils, Wagga Wagga, NSW. The timber galley, centre, was pulled by a Foden traction engine. The water cart is in the foreground. Up to 16 men were fed by the cook.
Photo courtesy Museum of the Riverina.



The galley today. Harold Fife, seated, tells his memories of the galley. Following recognition of its significance, the Museum of the Riverina has placed the galley under cover in a purpose-built shed where it is conserved in its original condition. Visitors are not allowed inside because of the fragility of its ageing timbers, including cracking floorboards. Instead, a platform has been constructed so that visitors can view inside its three openings and experience the galley as it was for much of its working life. *Photo courtesy Kylie Winkworth.*

Tips for preservation

Historic farm machinery can usually survive for long periods where it belongs, as long as there is basic security, protection from pests and shelter from the elements. Generally, don't leave machinery outside and exposed. The following tips will help you store and preserve historic farm machinery, in particular, if it is no longer in use or stored in a museum.

Paintwork, leather, felt, wood, paper

- Throw away the paintbrush and avoid pouring fluids on the machinery! Painting ruins old finishes and signwriting and can diminish the research potential of machinery, losing evidence of how it was used and made. It might cover details of where the machinery was manufactured or the scars of its use. Seek advice on other reversible products that can prevent rust.
- Store machinery away from direct sunlight to protect original paintwork and materials. Keep gutters clear and ensure that drainage keeps the storage shelter dry and humidity down.
- Clear out vegetable matter or remnants of grain that might attract pests or vermin. Keep a sample of the remnants in a sealed bag with the catalogue documentation. If you don't know what the machinery was used for, this will provide some clues.
- Watch leather, felt, wood, paper and surface dust for signs of insect and mould attack. Ensure good air circulation and keep them dust free. Avoid the use of leather dressings unless the leather is in use or part of a working display, otherwise it might attract insects and vermin.

Wheels, tyres and axles

- Put wheeled vehicles and farm implements on axle stands, so that the wheel is clear of the ground or floor. This reduces the potential for rust or insect damage from floor or ground contact. Metal stands are better than wood and should have enough base area to be stable when the item is raised.
- The stands will take the weight off rubber tyres which could cause cracking or flat spots.
- Let down pneumatic tyres, so they'll last longer.

Internal combustion engines and mechanical internals

- Where you can, drain old oils and fuels.
- Use appropriate lubricants for functional machines that are run from time to time.
- Use inhibited lubricants to protect mechanical internals from corrosion when they are in storage. Oil companies can advise on suitable products.
- Make sure any areas which hold water are drained, including radiators and cooling tanks. Drain and open spaces which were designed to be opened to allow thorough drying out.
- Often pockets of trapped water can be drained using a piece of cloth that acts as a wick.

Steam engines and boilers

- Rust can occur in combustion spaces and boiler tubes, smoke boxes, chimneys and in boilers and water tanks. Sweep and thoroughly wash out these areas and store them dry and open to ensure air circulation. Cover chimneys and other openings that allow access to moisture and other material.
- Insulating lagging over boilers is often made of materials that trap water and cause corrosion - all the more reason to store the machinery under shelter.
- Qualified operators are needed for working steam engines, which should be inspected annually and certified fit for use.

Security and safety

- Check for features which could injure or endanger visitors, such as sharp edges or corroded parts which could break. Fasten movable parts such as levers that could trap fingers or clothing in a way that is reversible. Use barriers and signage to warn of possible risks and warn children and ensure that they are adequately supervised by adults.
- If the significance of machinery allows you to operate it, keep visitors at a safe distance. Some machinery requires qualified operators and regular inspection. Seek advice on requirements in these areas.
- Protect small machinery parts from possible theft by securing them. Do not drill holes in machinery or parts, but instead try to secure them to an anchor point using plastic coated stainless steel fishing trace wire with suitable fittings.

throw away the paintbrush!

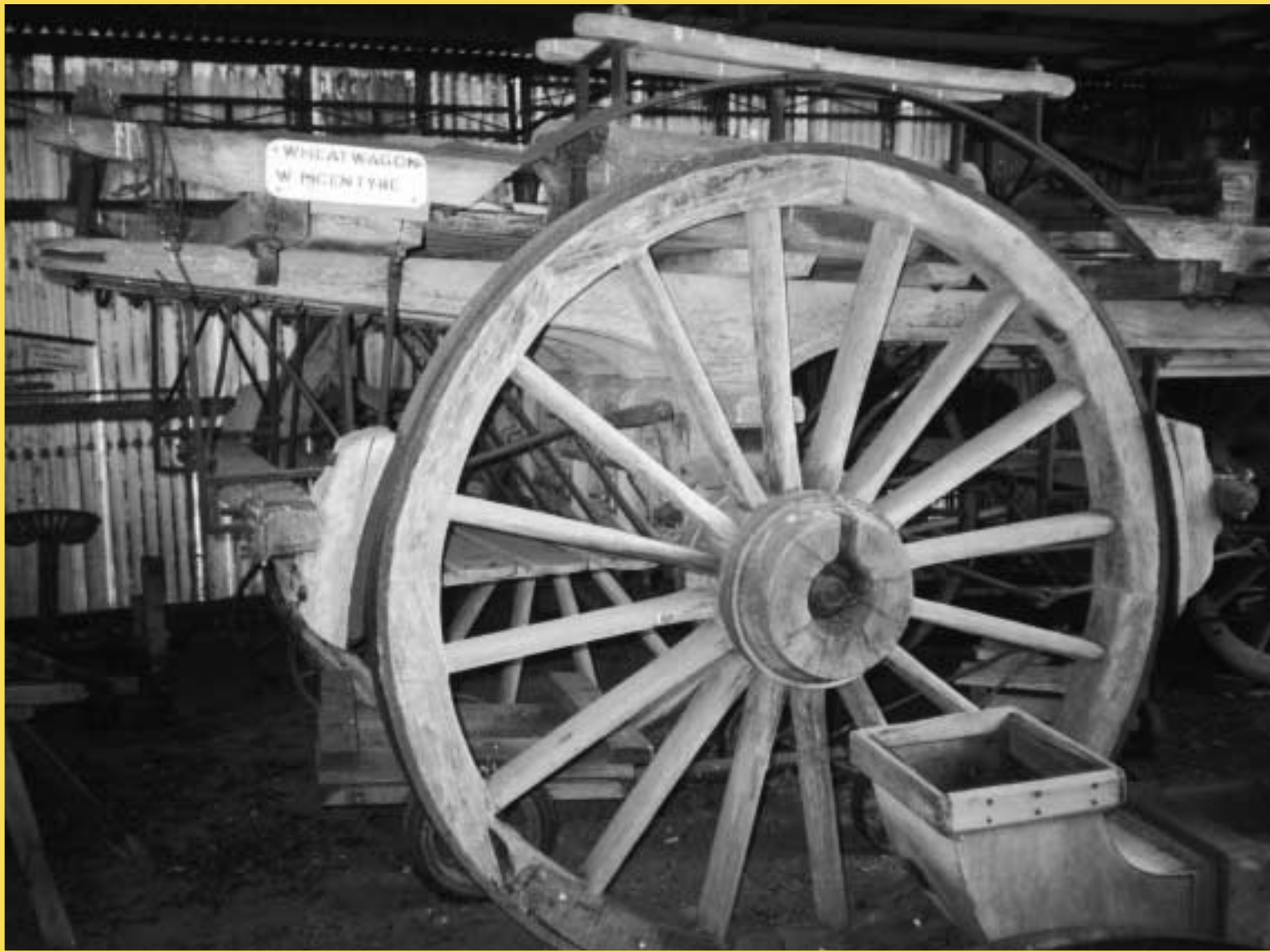

Wheat wagon, Temora, NSW. This wagon is in almost original condition and does not need to be repainted. Original finishes, signs of wear and tear and other evidence of its history of use in Riverina paddocks are retained for research. This enables visitors to appreciate what the wagon looked like during its working life.

Photograph courtesy Museum of the Riverina.

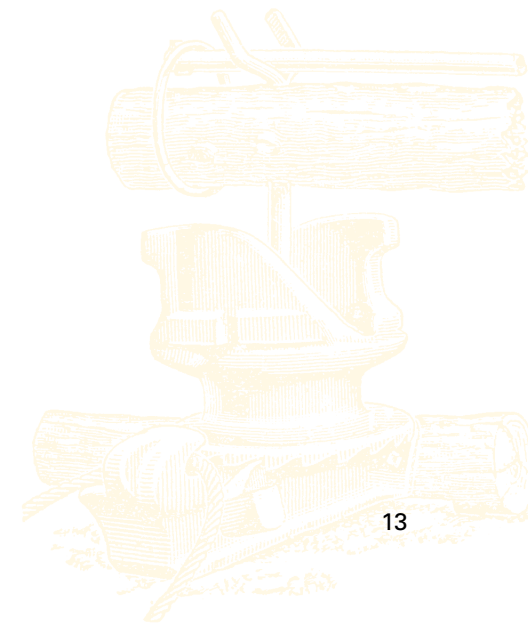

harvesting in paddocks

The machine is a 'Union' Nicholson and Morrow stripper-harvester that was manufactured between 1884 and 1914. James Morrow was an Irish immigrant in Melbourne who patented a stripper with a threshing attachment in 1883. The following year he patented and produced a stripper-harvester (as seen in the photo) which was the first successful machine of its type. A similar machine was produced by Hugh Victor McKay at the same time. Nicholson and Morrow closed down in 1914 when it was deemed a non-essential industry during the First World War.

Original photograph by Charles Kerry Studio, Tyrrell Collection, the Powerhouse Museum, Sydney. Reproduced with permission.



Let your machinery tell the story

Interpret the history of the machinery and its industry in your displays. People will be more interested in the wider story of your region and its people and places than just information on the name and type of machinery. This can be more interesting to people than operating the machinery. Remember that a large percentage of your visitors may have no knowledge whatsoever of farming practices!

Arrange the machinery so that you can trace the work processes step by step. Show old photos of the item in use and tell the stories about who worked it and where. How did the industry affect your local region and its life? How has the nature of work and the industry changed over time?

Museums sometimes believe that unrestored machinery is of no interest to a visitor, or worse, that it is an eyesore. Unrestored machinery can be of great interest and museums can lead by example with ethical preservation and thoughtful labelling.

Interpret the machinery using the statement of significance as a guide and explain the reason it is being preserved rather than restored or reconstructed and the benefits of leaving machinery in its original state, the way it was for most of its working life.

Don't forget to tell stories on your labels about the people who used the machinery and how it affected the landscape, environment and organisation of the farm.

New technology has made harvesting a more productive and less labour intensive task. It has also affected local employment. The once common trades associated with farm horses, for example, blacksmithing, have all but disappeared from the Riverina.

Photograph by Angus McGeoch, Wagga Wagga. Reproduced with permission.



Further information

Clegg, G "Preventive Conservation: Farm Machinery", Museum Methods, Museums Australia Inc, 1995

Keats, J "Conserving Our Farming History", NSW Agriculture Total and NSW Heritage Office, 1996

NSW Heritage Office and Ministry for the Arts Movable Heritage Project, "Movable Heritage Principles", 2000

NSW Heritage Office and Ministry for the Arts Movable Heritage Project, "Objects in Their Place: An Introduction to Movable Heritage", 1999

NSW Heritage Office and Department of Urban Affairs and Planning, "Regional Histories", 1996

Russell, R and Winkworth, K "Significance: A Guide to Assessing the Significance of Cultural Heritage Objects and Collections", Heritage Collections Council, 2001

Simpson, M and P "Old Farm Machinery in Australia: A Fieldguide and Source Book", 1991

Winkworth, K "Connecting Collections, Thematic Studies of Museum and Heritage Collections", Queensland Heritage Trails Network, 2000

Contacts

NSW Heritage Office

Level 11, Signature Tower
2-10 Wentworth Street
Parramatta 2124

Tel: 61 2 9635 6155
Fax: 61 2 9891 4688

Home Page: www.heritage.nsw.gov.au
E-mail: heritageoffice@heritage.nsw.gov.au

NSW Ministry for the Arts

Level 9, St. James Building
111 Elizabeth Street
Sydney 2000

Tel: 61 2 9228 5533
Fax: 61 2 9228 4722

Home Page: www.arts.nsw.gov.au
E-mail: ministry@arts.nsw.gov.au

Museums and Galleries Foundation of NSW

The Gunnery
43-51 Cowper Wharf Road
Woolloomooloo 2011

Tel: 61 2 9358 1760
Fax: 61 2 9358 1852

Home Page: www.mgfnsw.org.au
E-mail: webmaster@mgfnsw.org.au

Written by Graham Clegg, Powerhouse Museum, Thomas Graham, Museum of the Riverina, John Petersen, NSW Heritage Office and Kylie Winkworth, Heritage Council of NSW Movable Heritage Panel.

Thanks to: Madeleine Scully and Colin Carlin, Museum of the Riverina, Wagga Wagga, Sarah-Jane Rennie, Museums and Galleries Foundation of NSW, Harold Fife, David Walster, Garth Jones, Coolamon Shire Council, Don Godden and the Powerhouse Museum, Sydney.

ISBN 1 876415 52 5
HO 01/04
© Crown copyright 2001

Disclaimer

Any representation, statement, opinion or advice, expressed or implied in this publication is made in good faith but on the basis that the State of New South Wales, its agents and employees are not liable (whether by reason of negligence, lack of care or otherwise) to any person for any damage or loss whatsoever which has occurred or may occur in relation to that person taking or not taking (as the case may be) action in respect of any representation, statement or advice referred to above.

**Produced by NSW Heritage Office
and Ministry for the Arts
Movable Heritage Project**

Designed by O'Kelly & Associates



Abandoned house, Borambola, NSW.
Photograph by Angus McGeoch,
Wagga Wagga. Reproduced with
permission.



*Historic farm buildings and machinery reveal
how people once lived and worked on the land*



Triticale crop,
Wantabagery district, NSW.
Photograph by Angus
McGeoch, Wagga Wagga.
Reproduced with
permission.