

**GAP BLUFF
REVISED
EXHIBITION DRAFT**

DISCLAIMER

This report was prepared by Gap Bluff Hospitality in good faith exercising all due care and attention, but no representation or warranty, express or implied, is made as to the relevance, accuracy, completeness or fitness for purpose of this document in respect of any particular user's circumstances. Users of this document should satisfy themselves concerning its application to, and where necessary seek expert advice in respect of, their situation. The views expressed within are not necessarily the views of the Office of Environment and Heritage (OEH) and may not represent OEH policy.

© Copyright State of NSW and the Office of Environment and Heritage

CURRENT SIGNS TO BE RESTORED

a

CONSTABLES COTTAGE

BUILDING SIGNS



b

DIRECTIONAL SIGN

FOOTPATH SIGN



c

WARNING SIGN

FOOTPATH



d

THE GAP BLUFF CENTRE

ENTRANCE SIGN



e

EMERGENCY ACCESS

TRAFFIC



f

WARNING SIGN

FOOTPATH



02

VISITORS PARKING

TRAFFIC SIGN



h

OFFICERS MESS

BUILDING SIGN



NEW SIGNAGE

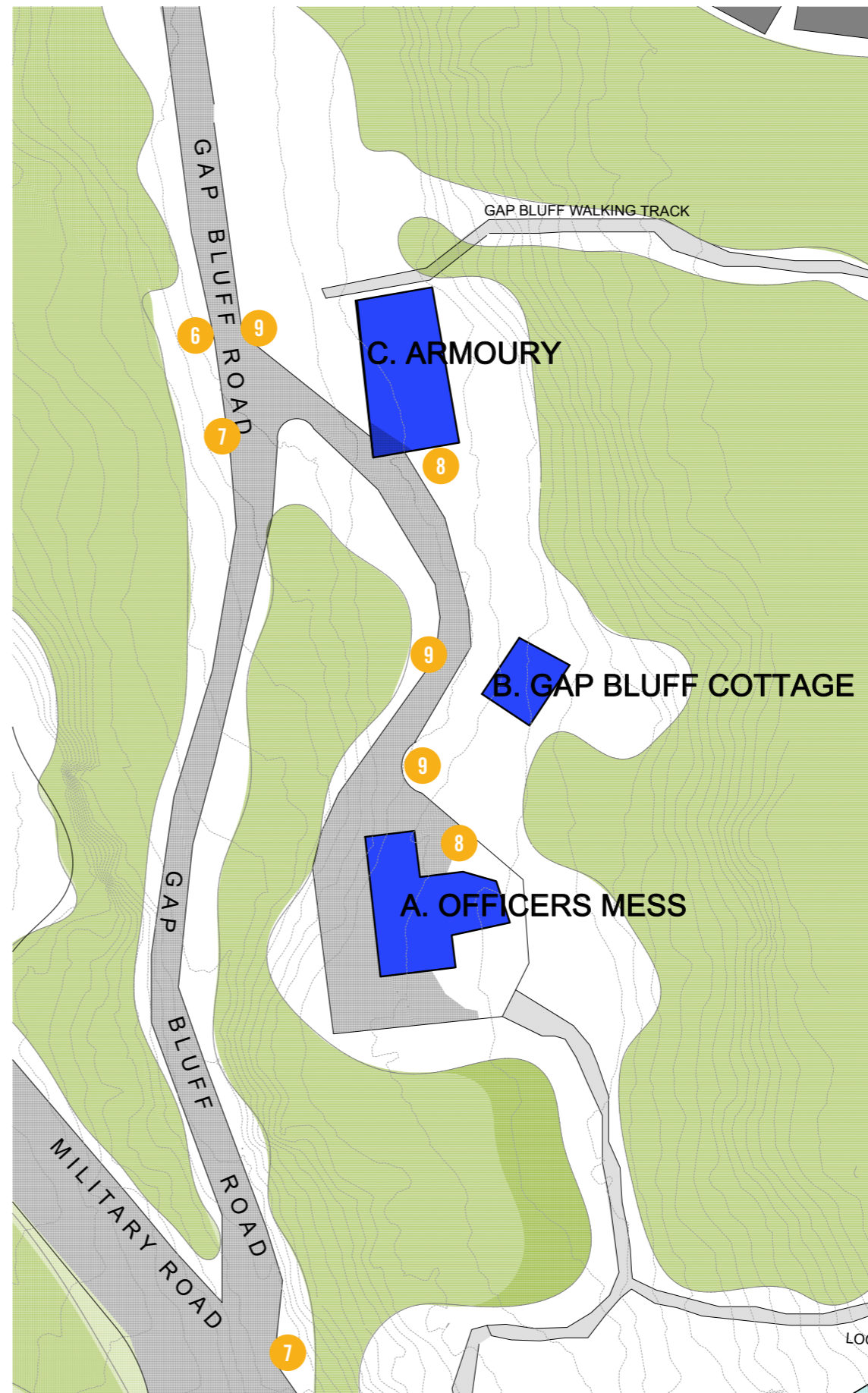

KEY

- 1. GAP BLUFF entrance A
- 2. GAP BLUFF entrance B
- 3. Parking permitted penalty
- 4. Emergency access no parking
- 5. Parking
- 6. Park in marked spaces only
- 7. Exit only
- 8. Disabled parking
- 9. Historic Interpretation Panel

POSITIONS OF SIGNS AROUND THE SITE

Location and orientation of signs to be confirmed on site in consultation with NP NSW and Gap Bluff Central before installation.

1

PRIMARY DIRECTIONAL SIGN A

CONTINUE STRAIGHT

DESIGN GUIDELINES

Construction principles: refer Park Signage Manual section 6.1

Graphics principles: refer Park Signage Manual section 6.2

Words and messages: refer Park Signage Manual section 6.3

Printing options: refer Park Signage Manual section 6.4

Siting and locating principles: refer Park Signage Manual section 6.6

Materials information: refer Park Signage Manual section 10

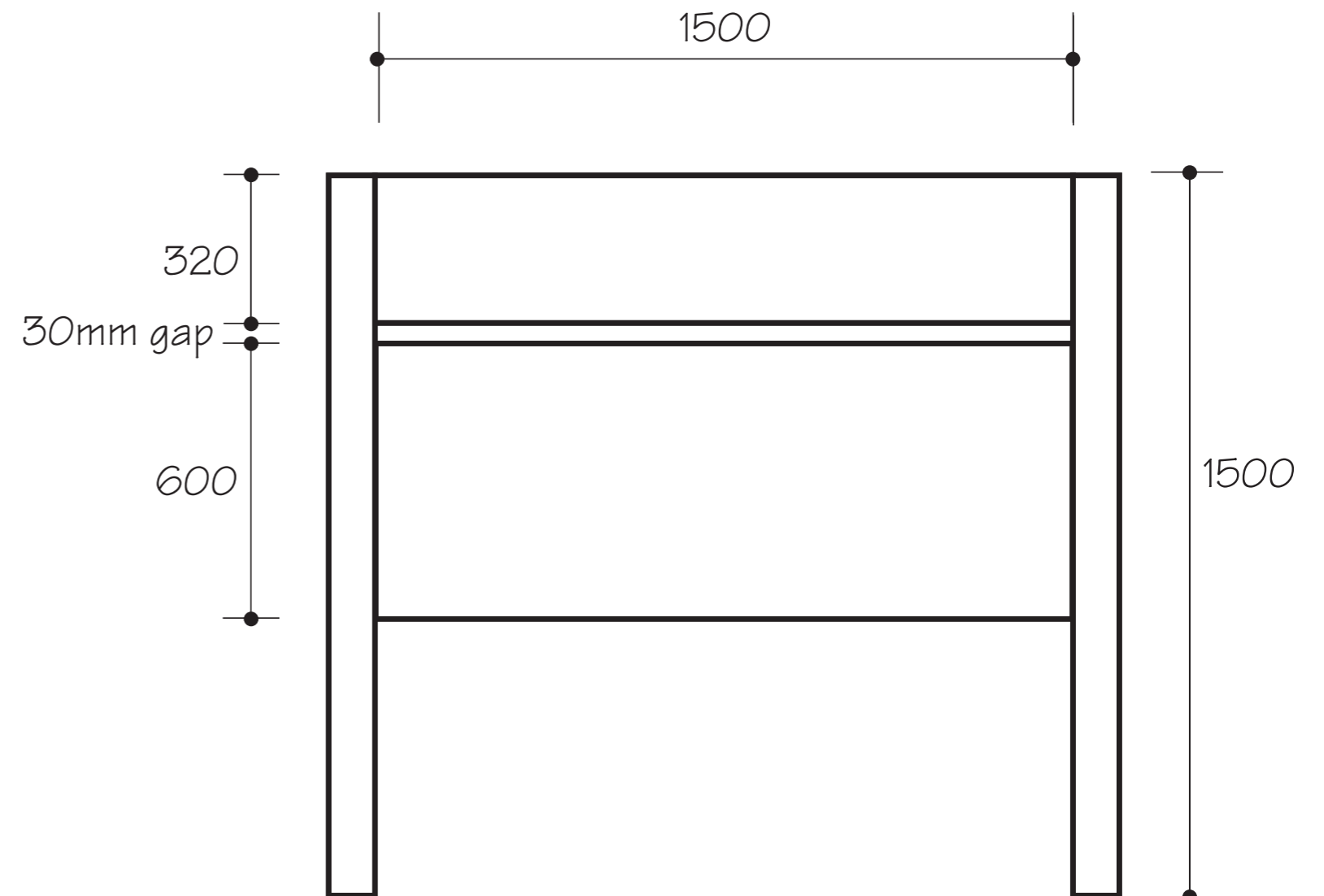
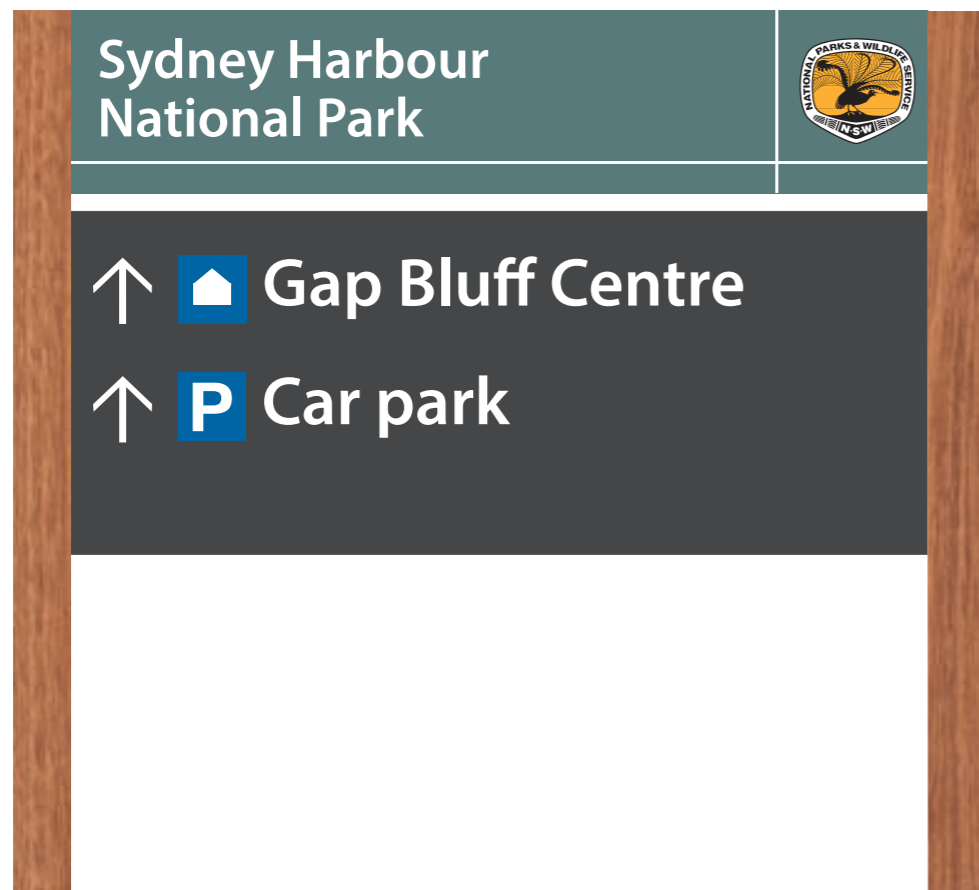

2

PRIMARY DIRECTIONAL SIGN B

CONTINUE RIGHT

DESIGN GUIDELINES

Construction principles: refer Park Signage Manual section 6.1

Graphics principles: refer Park Signage Manual section 6.2

Words and messages: refer Park Signage Manual section 6.3

Printing options: refer Park Signage Manual section 6.4

Siting and locating principles: refer Park Signage Manual section 6.6

Materials information: refer Park Signage Manual section 10

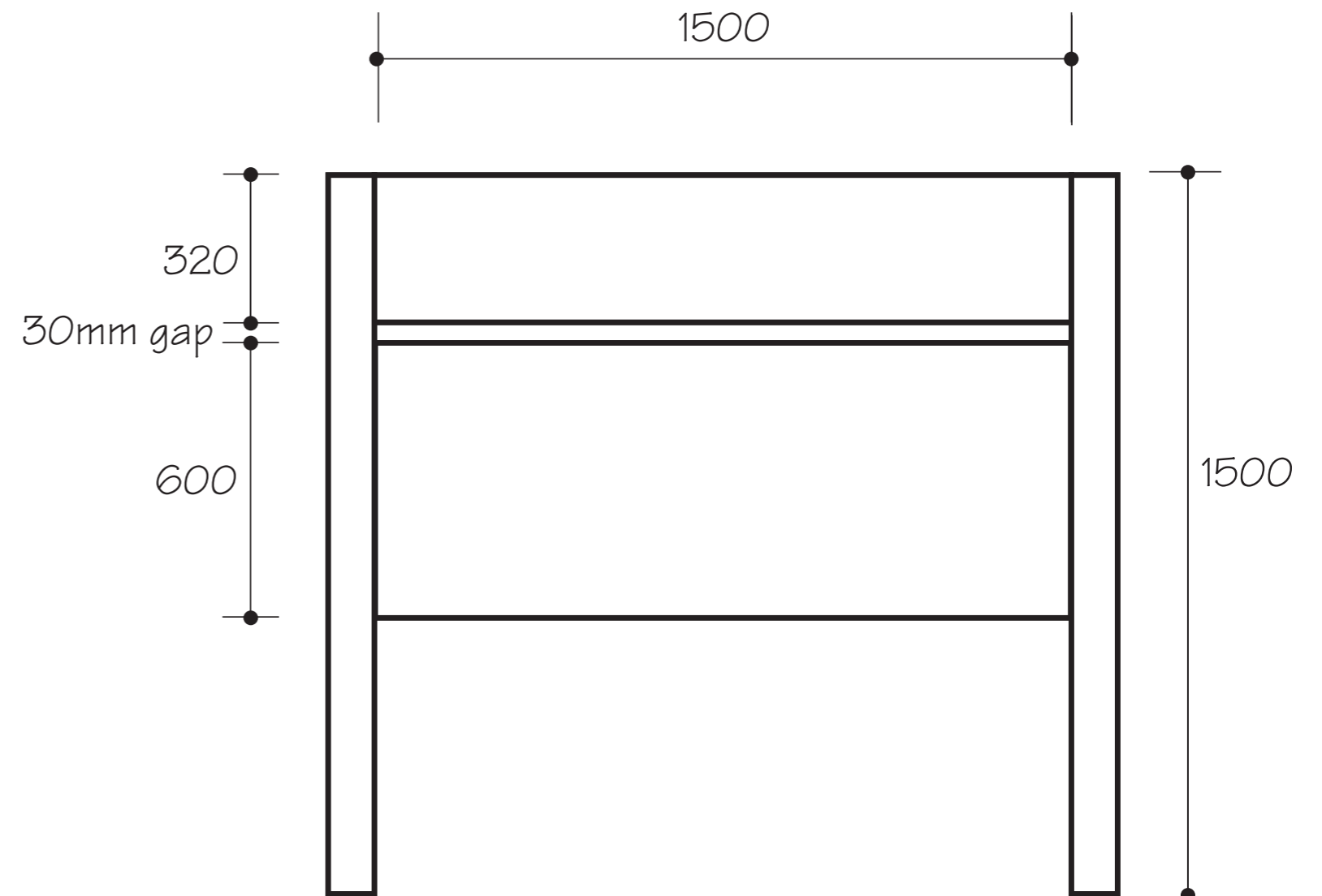
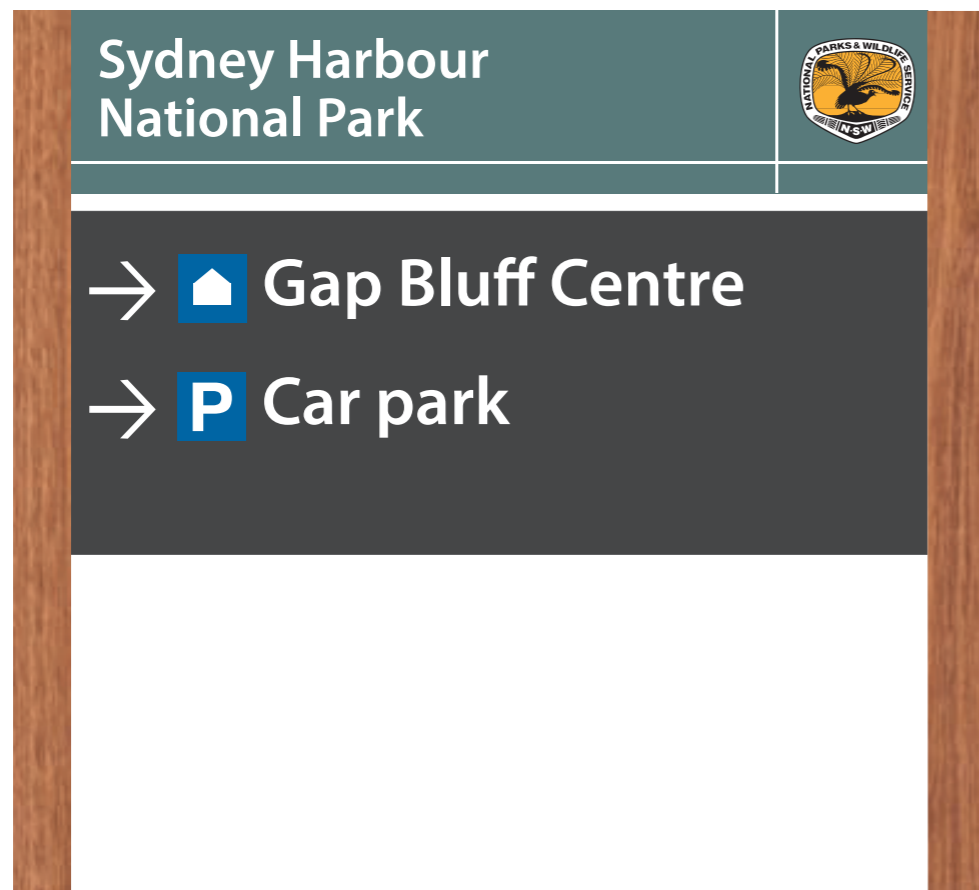

3

PARKING AND PENALTY

PARKING

Parking permitted for Gap Bluff Centre clients only.
No overnight parking.
Penalty: \$300

Pole Mounted

4

EMERGENCY ACCESS

PARKING

NO
PARKING
EMERGENCY
VEHICLE
ACCESS

Pole Mounted

5

PARKING

PARKING SIGN



Pole Mounted

6

PARKING IN MARKED SPACES

PARKING



Pole Mounted

7

EXIT ONLY

TRAFFIC



Pole Mounted

8

DISABLED PARKING

PARKING SIGN



Pole Mounted

9

HERITAGE INTERPRETATION PANEL

AT HERITAGE BUILDINGS

HERITAGE INTERPRETATION

This sign will have a historic photo of the relevant building and the history of the hall and site. Image and text to be decided.

DESIGN GUIDELINES

Construction principles: refer Park Signage Manual section 6.1

Graphics principles: refer Park Signage Manual section 6.2

Words and messages: refer Park Signage Manual section 6.3

Printing options: refer Park Signage Manual section 6.4

Siting and locating principles: refer Park Signage Manual section 6.6

Materials information: refer Park Signage Manual section 10

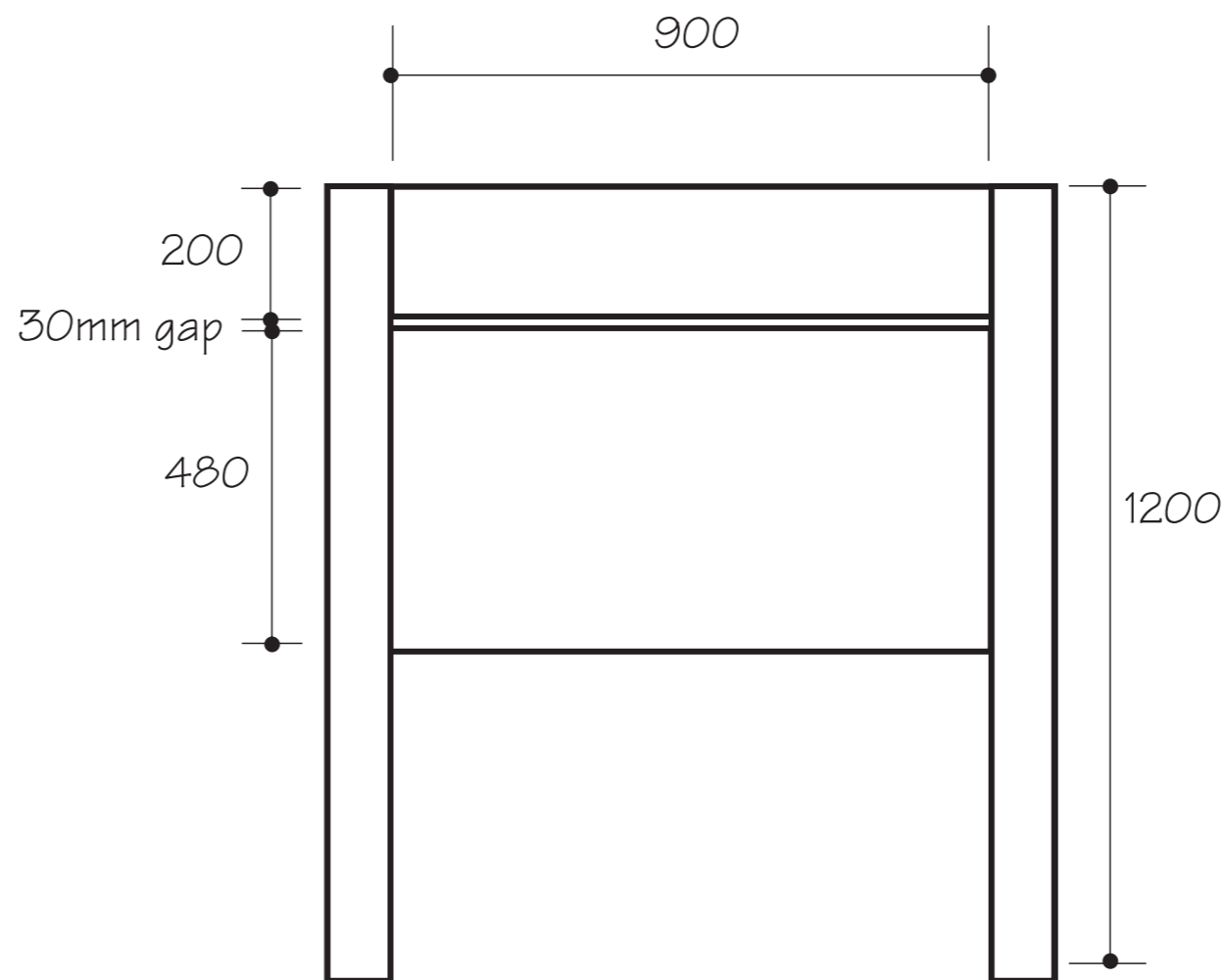
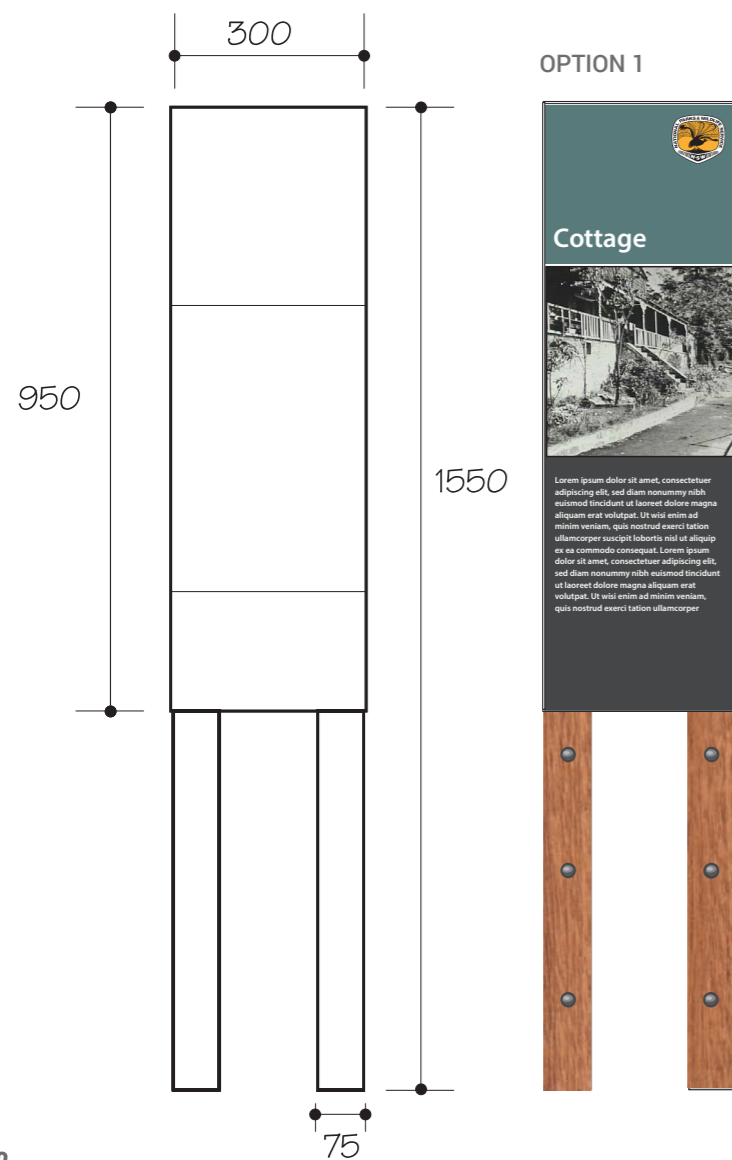

OPTION 2

